

Journal Info

ISSN: To be assigned
Scholaria Publications
Scholaria International Journal of Research
International Peer Reviewed Journal
2026, Volume 1 – Issue 1

Article Info

Received: 05 Feb 2026
Revised: 25 Feb 2026
Accepted: 10 Mar 2026
Published: 05 Apr 2026

DOI: Not Assigned
Article Type: Research Article

Recent Advances in Nanoscience and Nanotechnology: Nanoelectronics and Molecular Machines

¹Padala Srinivas, ²S Rama Krishna

^{1,2}Assistant Professor

^{1,2}Department of Electronics and Communication Engineering

¹Sasi Engineering College, India

²MIC Institute of Engineering and Technology, India

Abstract

Nanoscience and nanotechnology have emerged as significant multidisciplinary fields, integrating concepts from physics, chemistry, biology, and engineering. The growing attention in this domain is driven by two primary factors. First, materials at the nanoscale exhibit unique and enhanced properties, making them highly suitable for advanced technological applications. Second, the nanoscale regime provides vast opportunities for exploring size-dependent physical phenomena and uncovering previously unobserved material behaviors. Nanostructured materials play a crucial role in the development of innovative devices with superior performance characteristics. In particular, one-dimensional nanostructures such as nanotubes, nanowires, and nanorods represent an important class of materials with promising applications in electronics, composite systems, and sensing technologies. These structures demonstrate physical and electronic properties that differ significantly from their bulk counterparts. For instance, charge transport mechanisms in one-dimensional systems exhibit distinct behavior compared to bulk materials. While theoretical researchers focus on modeling and understanding these nanoscale phenomena, engineering and technological efforts are directed toward translating these properties into practical devices and applications.

Keywords: Nanoscience, Nanomaterials, Nanoscale Devices, Material Synthesis, Low-Dimensional Systems

1 Introduction**1.1 Background of Nanoscience and Nanotechnology**

The rapid progress observed in nanoscience and nanotechnology today originates from foundational ideas proposed by prominent scientists in the twentieth century. Among these contributors, Richard P. Feynman stands out as a key figure. On December 29, 1959, at a meeting of the American Physical Society held at the California Institute of Technology, he delivered his renowned lecture titled “*There is Plenty of Room at the Bottom*” [1].

In this presentation, Feynman introduced the concept of controlling and arranging matter at extremely small scales, specifically at the level of atoms. He argued that the fundamental laws of physics do not prevent the precise manipulation of individual atoms, suggesting that

such control is theoretically achievable. He further proposed the possibility of constructing extremely small electronic circuits, with dimensions in the nanometer range, which could lead to significant advancements in computing technologies.

Nanotechnology can be broadly described as the ability to design and manipulate materials at the molecular or atomic scale, enabling the construction of systems with precise structural control. This approach allows the development of nanoscale devices and machines with tailored properties and functions.

Recognizing the transformative potential of this field, the United States National Science and Technology Council (NSTC) established a coordinated working group on nanoscience, engineering, and technology in 1998. Subsequently, in 2001, the National Nanotechnology Initiative (NNI) was launched with substantial governmental funding [3]. The initiative aimed to promote collaboration among academic institutions, industry, and private organizations to accelerate research and innovation in nanotechnology. Inspired by this effort, numerous developed and developing nations, including China and India, have made significant investments in advancing research and development in this domain.

2 Translation Tools

Although the term nanoscience and nanotechnology is relatively recent, many natural systems have long exhibited structures and functions at micro- and nanoscales. Numerous examples from nature illustrate this concept. One such example is the abalone, a type of mollusk, which forms a highly durable shell with remarkable fracture resistance. Scientific investigations have shown that this exceptional strength arises from a hierarchical structure composed of nanoscale calcium carbonate (CaCO_3) platelets bound together by an organic matrix consisting of proteins and carbohydrates.

Another example can be found in biological systems such as bacterial flagella. These microscopic structures function as rotary motors, capable of rotating at speeds exceeding 10,000 revolutions per minute [4]. The motion is powered by proton transport driven by an electrochemical gradient across the cell membrane. Notably, the structural components of this motor operate at extremely small dimensions, with bearing sizes on the order of 20–30 nm and clearances as small as 1 nm. Such systems demonstrate the presence of highly efficient nanoscale machinery in living organisms.

Historical evidence also indicates that early human civilizations unknowingly utilized nanoscale materials. For instance, stained glass used in medieval churches achieved vibrant colors through the incorporation of nanosized metal particles dispersed within the glass matrix. Similarly, the development of photography in the eighteenth and nineteenth centuries relied on the formation of nanoscale silver particles produced through the interaction of light with silver halides. These particles served as the fundamental units for image formation.

George Eastman, the founder of the Kodak Company, introduced one of the earliest practical applications of this concept by developing photographic film composed of paper coated with silver halide. This innovation can be regarded as an early example of the commercialization of nanoscale technology. However, it is important to note that, unlike modern nanotechnology, these earlier applications lacked a detailed scientific understanding and precise control over nanoscale structures.

3 Some Special Topics in Nanotechnology

The advancement of modern society has been closely linked with the development of new materials, particularly during the twentieth century, which introduced a wide range of substances

with transformative impacts. One notable milestone was the emergence of silicon-based technologies in the 1940s, often referred to as the “silicon revolution,” which significantly influenced economic growth and technological progress. With the rise of nanotechnology, it is widely anticipated that the twenty-first century will witness another major technological shift driven by the development of highly efficient and advanced materials. Among these, carbon-based nanostructures are expected to play a crucial role.

3.1 Nanoelectronics

In the 1960s, Gordon Moore, a co-founder of Intel, observed a trend—later termed Moore’s Law—stating that the number of transistors integrated on a chip tends to double approximately every 18 months. This pattern has persisted for several decades, leading to a continuous reduction in device dimensions. As a result, feature sizes in electronic components have approached the nanometer scale, where quantum mechanical effects begin to dominate over classical behavior.

One important nanoscale device is the tunnel junction, which consists of a thin insulating layer placed between two conducting electrodes. The electrical characteristics of such a structure depend on electron tunneling, a quantum phenomenon where electrons pass through the barrier. The efficiency of this process is highly sensitive to the barrier thickness and the available electron modes.

A notable application of this principle is the single-electron transistor (SET), which utilizes discrete charge transfer at the nanoscale. In a simple configuration known as a single-electron box, replacing a conventional resistor with a tunnel junction results in quantized charge transfer. Instead of a continuous variation, the charge increases in discrete steps, a behavior commonly referred to as the Coulomb staircase.

The SET can be considered an extension of this concept, incorporating two tunnel junctions that allow controlled electron movement onto and off a small conducting region known as an island. The energy required to add an electron to this island depends on electrostatic interactions and can be modulated using a gate voltage.

There are two primary implementations of single-electron transistors. In the metallic version, thin metal films (such as aluminum) are deposited to form electrodes, and thin oxide layers act as tunnel barriers. In contrast, the semiconducting version is based on structures formed within a two-dimensional electron gas, typically at semiconductor interfaces such as GaAs/AlGaAs. In this case, confined regions—often called quantum dots—restrict electron motion in all spatial directions, leading to atom-like behavior.

For electron transport to occur in such devices, the system must overcome an energy barrier known as the Coulomb energy. When the applied voltage is insufficient, electron flow is suppressed, a phenomenon called Coulomb blockade. As voltage increases, electrons can tunnel through the system once the required energy threshold is reached. The voltage corresponding to this transition is referred to as the Coulomb gap.

Despite their promising properties, integrating single-electron devices into practical circuits remains a significant challenge. Establishing reliable interconnections and scaling these systems into functional architectures require innovative approaches. Proposed solutions include combining these devices with conventional semiconductor technologies or employing alternative concepts such as quantum cellular automata, where interactions between localized charge states enable information processing without traditional wiring.

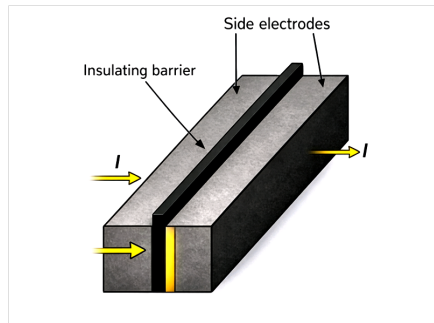

Figure 1: Schematic structure of a tunnel junction consists of a very thin insulating barrier sandwiched between two metallic electrodes.

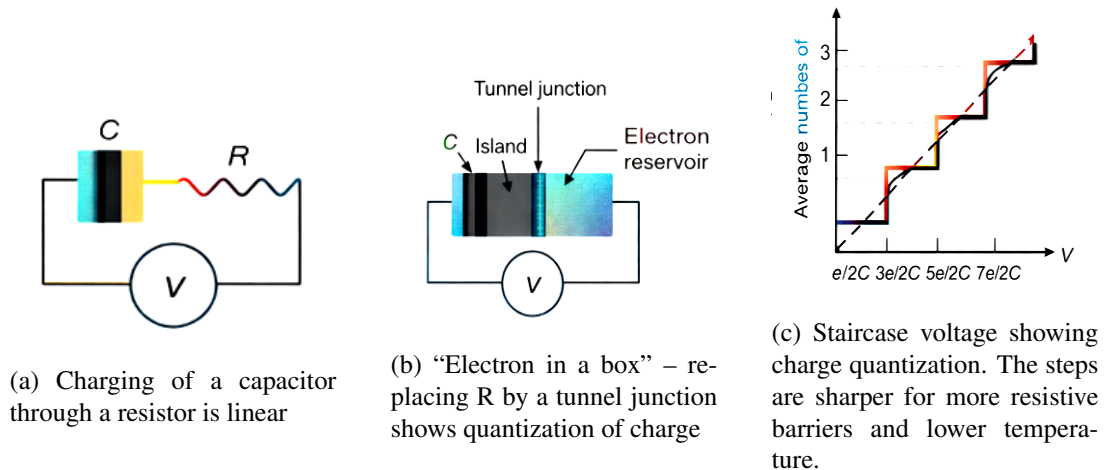

Figure 2: quantization process and Coulomb staircase

4 Conclusion

Carbon nanotubes have been explored as conductive connections between sequences of insulating nanoclusters, enabling novel device architectures. In such systems, binary states ("0" and "1") can be represented through polarization orientations controlled by an external electric field. Quantum Cellular Automata (QCA) provide a framework for constructing complex computational circuits based on these principles.

One of the key benefits of QCA is the extremely rapid transmission of information between cells, driven by electrostatic interactions rather than physical wiring. This mechanism allows signal propagation at speeds approaching that of light. Additionally, QCA structures eliminate the need for conventional interconnects, and their cell dimensions can be reduced to only a few nanometers (on the order of 2.5 nm). These characteristics make QCA a promising candidate for ultra-dense memory systems and future quantum computing technologies.

References

- [1] R. P. Feynman, "There's Plenty of Room at the Bottom," *Engineering and Science*, vol. 23, pp. 22–36, 1960.
- [2] K. E. Drexler, *Engines of Creation: The Coming Era of Nanotechnology*. London: Fourth Estate, 1990.

- [3] National Science Foundation, “Nanotechnology Research Reports,” 2000. [Online]. Available: <https://www.nsf.gov>
- [4] C. J. Jones and S. Aizawa, “The bacterial flagellum and its motor: structure, assembly, and function,” *Advances in Microbial Physiology*, vol. 32, pp. 109–172, 1991.